

LR-3000 Reader and Tags – Quick Installation Guide

If you are new to the LR-3000 Reader, or if this is your first long-range reader installation, we suggest that you call AWID Technical Support at 408-825-1100.

The LR-3000 Reader is a long-range Radio Frequency Identification reader for AWID’s UHF vehicle tags and hand-held cards. This Guide describes installation using the **Wiegand** interface. For RS-232 interface, download AWID’s Technical Reference.

Preparation

- **Layout Plan:** Ideal conditions for the installation site are –
 - ▶ One vehicle length or more between the reader and the gate.
 - ▶ Vehicles driving in the lane that is nearest the reader, in a straight line, at up to 15 miles per hour.
 - ▶ Reader mounted on a bracket with pan-and-tilt adjustable head for aiming the reader toward the tags.
 - ▶ Reader location and height consistent with the vehicle class and tag selection.
 - ▶ Reader and tags aligned, facing each other head-on (parallel to each other) at the reading distance – up to 25 feet.
 - ▶ Best tag location determined by tests on vehicles before attaching the tags. (Read the tag’s Instructions.)
- **Power Supply:** A separate dedicated DC power supply for each LR-3000 reader, connected to nothing else. For a 12-14 volt DC supply, current rating = 2 amperes or more, linear rated, regulated DC out. Install power supply 12 feet or *more* from the reader.
- **Cable:** May be separate cables for data and for power, or may be combined for data and power together. Max. length = 500 feet. For power alone – 18 gauge, 2 conductors, stranded wires, color-coded, overall shielded, high quality; 12 feet or *more* long. For data alone – 22 gauge, 3 conductors, stranded wires, color-coded, not twisted pairs, overall shielded, high quality. For combined cable – 18 gauge, 5 conductors, stranded wires, color-coded, not twisted pairs, overall shielded, high quality.
- **Mounting:** Adjustable pan-and-tilt bracket (see AWID’s Part No. LR-MB-0-0), required in most installations.

Seeing the Reader Work Before Installation (Use the Quick Installation Guide for LR-TEK Test/Demo Kit)

- The LR-3000 is “self-testing”. Add just a DC source and a tag. → Cut off and discard the connector on the reader’s cable.
1. Set up in a large open space. Hang the reader 6 feet above the floor, facing a distant wall. Use the power supply or a battery.
 2. The reader’s **red** LED indicates correct DC power. The **green** LED flickers on every time that the AWID tag’s code is read.
 3. Connections for self-test: Twist the reader’s **yellow** and **black** wires together. Connect the reader’s **black** wire to the power source’s DC negative. Connect the **red** wire to DC positive. There is no need to mount the reader or interface it to a panel.
 4. One-person testing: Use the LR-Sounder from the LR-TEK Test/Demo Kit. The Sounder’s beeper and LED let you detect reads at a greater distance. See Figure 1 (below) for this hook-up. Clip the **black**, **orange** and **red** leads to the LR-3000 reader.
 5. Holding the tag: Squeeze the tag at its edge. Hold the tag at arm’s length to your side. Have the tag and reader facing each other.
 6. Procedure: Power up the reader. Select one tag from the Kit or the job site. Present the tag to the reader. Measure (a) the read range (maximum distance “R” where the tag reads), and (b) maximum width “W” of the effective RF field at half-range.
 7. Results: When the tag is in the RF field (Figure 2), the LED flashes 3 times per second. Maximum range “R” may be 35-40 feet.

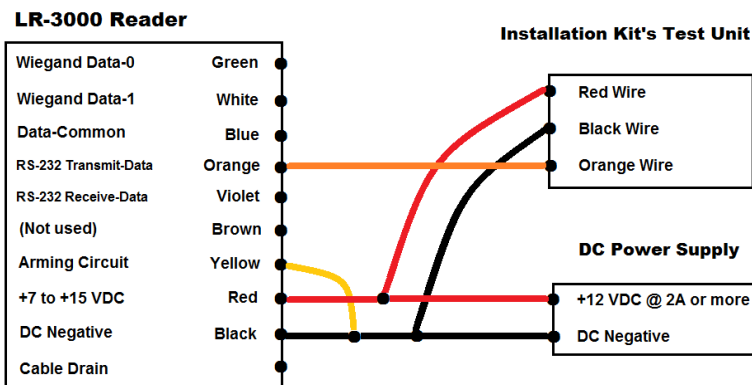

Figure 1. Connections for Pre-Installation Testing

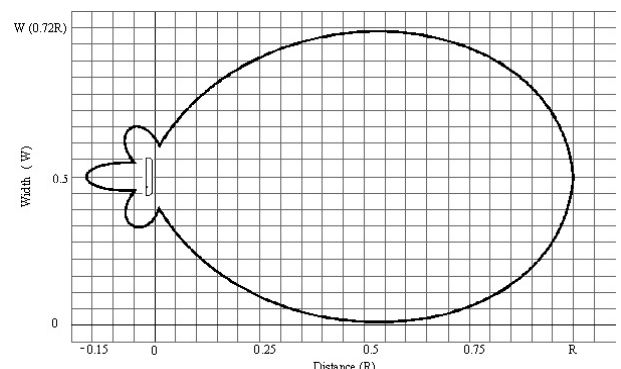

Figure 2. Effective RF Field for LR-3000 Reader

Mounting the Reader (For more information, see LR-3000 Installation & Operation Manual, Sections 5, 8 and 9)

1. Fasten the mounting bracket to the pole, post, pedestal, wall or beam. Leave space for the reader unit's pan-and-tilt adjustment.
2. Fasten the reader to the bracket with 2 ¼"-20 screws. AWID's LR-MB bracket includes fasteners.
3. Aim the reader toward the location of tags when they are attached to vehicles, for the planned reading distance (up to 25 feet).

Wiring the Reader (for Wiegand Interface) (Study Figure 3 carefully. There is no wiring for the reader's LEDs.)

1. Check the power supply and cable(s) for power and data. Be certain that they meet AWID's specifications ("Preparation", p. 1).
2. Connect the wires -- **yellow** to **black** at the reader; **black** and **red** to the power supply; **green** and **white** and **blue** to the controller.
3. Connect the reader's **drain** (shield) wire to the shields of all cables. **Do not ground** drain and shields – they must float.
4. Keep the reader's **orange** wire available for connecting the LR-Sounder test unit. Insulate **violet** and **brown** wires separately.
5. Do not tape or bead the wire junctions until the complete system has been tested thoroughly. Keep all junctions accessible.
6. Test the reader using the reader's green LED or the Kit's LR-Sounder. Watch for LED flash. (The Sounder's beeper will sound.)

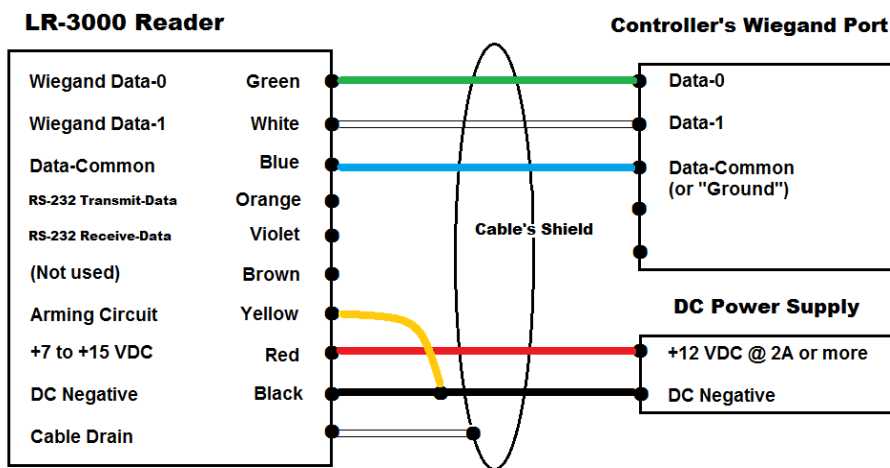

Figure 3. Wiring the Complete System for Wiegand Interface

The **blue** wire is Wiegand Data Common. It connects where a proximity reader's black wire would connect on that reader port. The terminal is usually labeled "Ground". If there is a "Common" terminal on that reader port, connect the **blue** wire there instead of "Ground".

Using the Credentials

- Select a location for the tags or cards that has clear line-of-sight to the reader. Tags and reader should be aligned, facing each other at the reading distance. Use the instructions that AWID shipped with the tags and cards.

WS-UHF, RV-UHF, SV-UHF tags: Secured permanently by their own adhesive. They will not read if they are removed..

VT-UHF, PT-UHF, HT-UHF tags: Supported by a visor clip or a fastener tape or a hook. They are easily moved and re-used.

MT-UHF, ST-UHF tags: Use mechanical fasteners to hold the tags in position. They are semi-permanent.

KT-UHF, HT-UHF tags; **CS-UHF, GR-UHF** cards: Held in your fingers and presented to the reader at the reading zone.

Programming the System

1. Complete the LR-3000 reader's interface to the host access control or vehicle identification system.
2. Program the application system for the type of reader, and for the tags' code format, facility (or site) code, and card numbers.
3. Assign suitable programming for the individual tags in the cardholders' database – gate groups, time zones, priority levels, etc.
4. Program the applications for the action to be taken for each valid read – gate motor operation, data recording, reports generation.

Testing the Completed System

1. Drive a vehicle with an attached tag into the read zone on the lane. Observe the code registered by the system for accuracy.
2. Test operation of all functions by driving a vehicle with an authorized tag code past the reader and through the gate repeatedly.
3. Study the PC monitor's data display for full and correct information about events on the system. Watch for "Access granted".
4. Request a report of events logged in the system – for individual vehicles in a time period and for history at a single gate.

If a Problem Occurs ••• In the U.S. call **Technical Support**, 1-800-369-5533, 5:00 a.m. - 4:00 p.m. Pacific Time •••

1. Talk with an AWID Technical Support representative. || Leave a message on the Web site. || E-mail support@awid.com.
2. On the Web site, download Technical Support memo "Support 4 – Trouble-Shooting". It will identify and cure problems.